

# Especificaciones Técnicas ACO-VIC 1500



## DESCRIPCIÓN

Calefacción infrarroja eléctrica de onda corta, modelo **ACO-VIC 1500** con un emisor dicróico de tubo de cuarzo con revestimiento multicapa GOLD sin brillo de 1,5 Kw, preparada para climatizar en exteriores. Incluye cable de 3 metros, enchufe tipo schuko, y soportes a pared y sombrilla.

## ESPECIFICACIONES TÉCNICAS

Alimentación eléctrica: 220-240V / 1 Fase/ 50 Amperios  
Intensidad Máxima: 6,5 Amp  
Potencia: 1500 W  
Peso: 1.7 Kg  
Dimensiones: 480 mm x 120 mm x 120 mm (Sin soportes)  
Mínima altura de instalación = 1800 mm  
Vida útil de la lámpara: - 5000 Horas

## ESQUEMA DE CONEXIÓN ELÉCTRICA

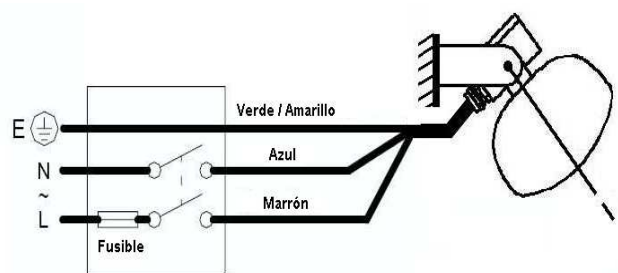

## ESQUEMA DE INSTALACIÓN

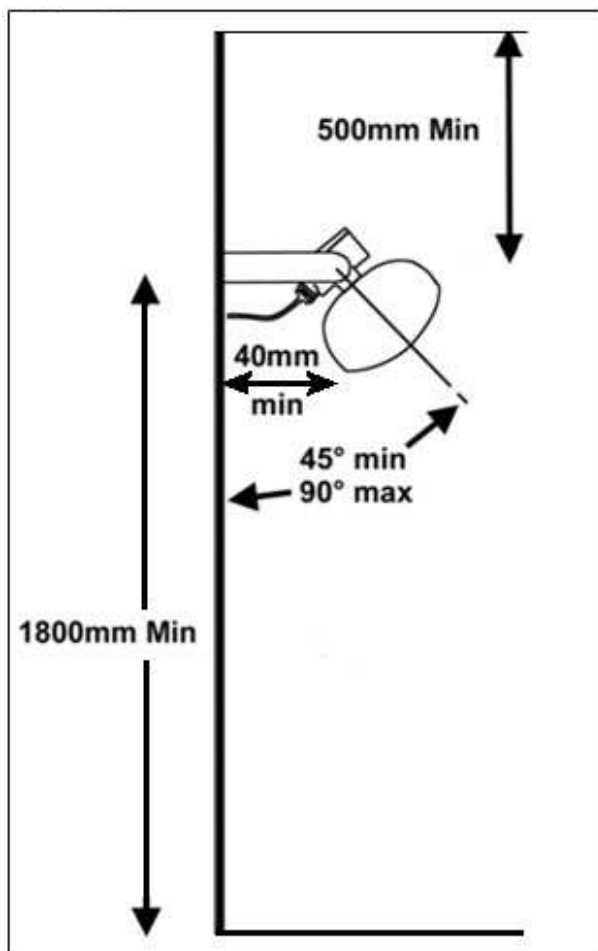

## DESPIECE DE LA UNIDAD

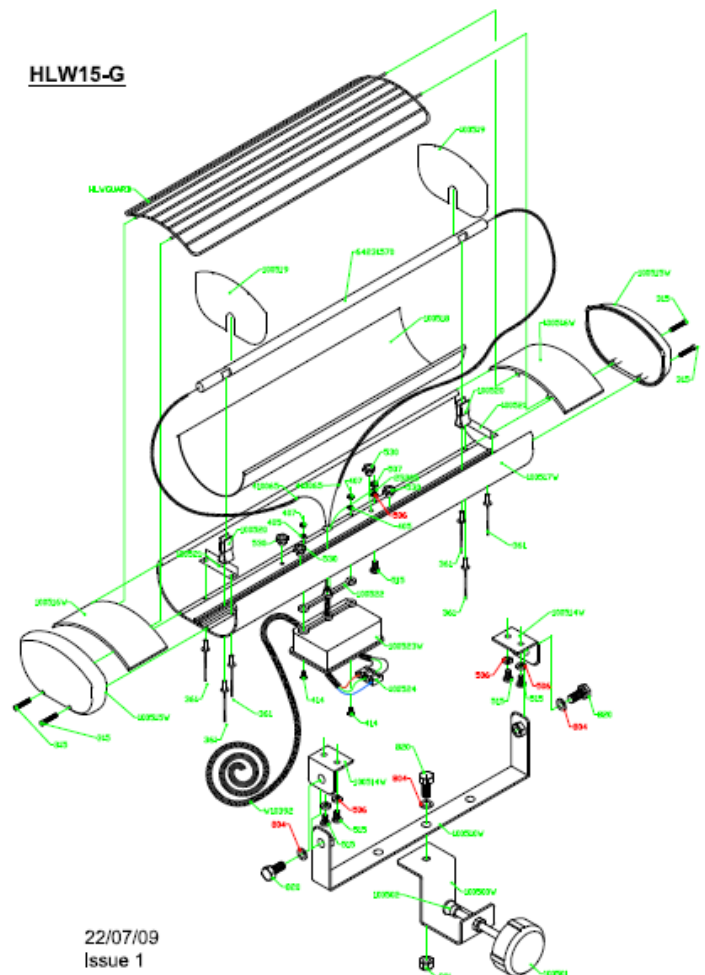

DECLARACIÓN DE CONFORMIDAD CE

**Victory (HeatLight Technology)**

Unit 3, Eastman way  
Hemel Hempstead  
HP2 7DU UK  
Tel: +44 (0) 1442 215200  
Fax: +44 (0) 1442 210050

**EC DECLARATION OF CONFORMITY**

**Models**

**HLW10, HLW15, HLW20**

Short wave IP55 Infrared fixed heating appliances

The above models have been manufactured in accordance with the following Directives.

93/68/EEC CE Marking Directive

2006/95/EC Low Voltage Directive

2004/108/EC EMC Directive

2002/96/EC WEEE Directive

2002/95/EC RoHS Directive

And the following harmonised standards

BS EN 60335-1:2002

BS EN 60335-2-30:2009

BS EN 55014-1:2006 + A1: 2009

BS EN 61000-6-30:2009

Signed:-



Name:-

Alan Penman

Position:-

Managing Director

Date:-

28<sup>th</sup> November 2012



This product conforms to EU Directive 2002/96/EC.

This appliance bears the symbol of the crossed waste bin. This indicates that, at the end of its useful life, it must not be disposed of as domestic waste, but must be taken to a collection centre for waste electrical and electronic equipment. It is the user's responsibility to dispose of this appliance through the appropriate channels at the end of its useful life. Failure to do so may incur the penalties established by laws governing waste disposal.